

Superior Waste and Recycling Containers



Custom Colors



Custom Stamping



Superior Designs



Cost Effective Solutions



PROUDLY MADE IN NORTH AMERICA !



Deskslider Recycling Container



**Recycling Products
made from
Recycled Content**



- Conveniently fits underneath your desk.
- Collects a perfect stack of 8.5" x 11" (making collection more efficient).
- Custom stamping available.
- Custom colors available.

Dimensions: 14.5" L x 11" W x 7" H



Hanging Waste Basket



- Will hang on any deskside recycling container.
- Significantly increases waste diversion rates (eliminates lazy tosses).
- Rounded corners and edges make it simple to clean.
- Custom stamping available.
- Optional lid available.
- Plastic liners available.

Dimensions: 7.5" L x 5" W x 6.5" H

Recycling Waste Baskets



- Fits perfectly against any desk.
- Custom stamping available.
- Available in a wide variety of colors.
- Available in 14 Quart and 28 Quart sizes.



Dimensions: 14 Quart: 11.24" L x 8.25" W x 12.24" H

28 Quart: 14.25" L x 10.5" W x 15" H

 **Minimum 25 - 55 % Post Consumer Content**

CALL US FOR RECYCLING ADVICE

The New 'Waste Watcher'

A popular space efficient bin . . . done right.

- Attractive streamlined look with no visible bag.
- Ideal for schools, lunchrooms, libraries, homes and offices.
- The size and shape allow for efficient use of space in high traffic areas.
- Custom openings to meet your specific needs.
- Lockable Lid available; making it a document destruction container.



Now the bag is hidden !



Dimensions: 11" L x 20" W

Available in 24", 27" and 30" in height

See page 5 for a list of available labels



Document Destruction

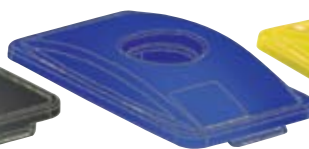

Cans/Bottles



Waste

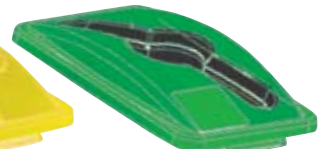

Mixed Recycling

Premium Containers

- Narrow profile allows for tight fit in high traffic areas.
- Round or rectangular openings available, (paper, waste, cans and bottles).
- Optional labels available.



Minimum 25 - 55 % Post Consumer Content

RECYCLING & WASTE CONTAINER SOLUTIONS

26 Gallon Upright with Clearview Lid



- Significantly reduces contamination.
- Ideal educational tool in schools.
- Hot stamped openings will not fade.
- Custom openings accommodate only desired content.
- Optional Recycling & Waste Sorting Cart.
- 26 Gallon capacity.

Dimensions:

17.25" L x 17.25" W x 28.75" H (with Lid)

17.25" L x 17.25" W x 22.5" H (without Lid)

Available Openings:

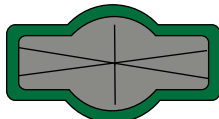

Mixed Recyclables
10 1/2" x 5"

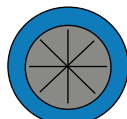

Cans / Bottles
3 1/4" or 5 3/4"

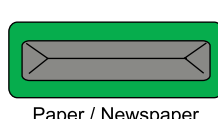

Paper / Newspaper
3" x 13"

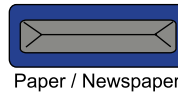

Paper / Newspaper
2" x 10.5"

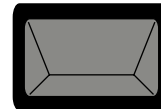

Plastic / Waste
6" x 10"



Self Closing Flap
6" x 10"



Upright Series

- Upright Series available in 7, 14 and 26 Gallon capacity.
- Optional metal snap handles.
- Optional lid.
- Customized lid openings available.
- Custom stamping and labels available.

Dimensions: 7 Gallon: 11.38" L x 11.38" W x 14.25" H

14 Gallon: 14.5" L x 14.5" W x 18" H

26 Gallon: 17.25" L x 17.25" W x 22.5" H



Minimum 25 - 55 % Post Consumer Content

THE MOST EFFECTIVE RECYCLING SOLUTIONS

The 'Smart Sort'

- Specific openings make for a quality sort.
- Color coded opening promotes proper separation.
- Custom labels make it simple for the end user.
- Convenient size and shape.
- 22 Gallon capacity allows for easy handling.
- Constructed of durable, dent resistant polyethylene.
- Clear Liner bag available.



Dimensions:

15.5" L x 14" W x 33.5" H (with Lid)

15.5" L x 14" W x 26" H (without Lid)

Plan for a Quality Sort



Paper Opening
13"L x 1.5"W



Mixed Opening
13"L x 1.5"W x 5"D



Circular Opening
5" D



Waste Opening
9"W x 6"H



Self Closing Flap
6" x 10"

Smart Sort Label Options



 **Minimum 25 - 55 % Post Consumer Content**

Super Sorter Series

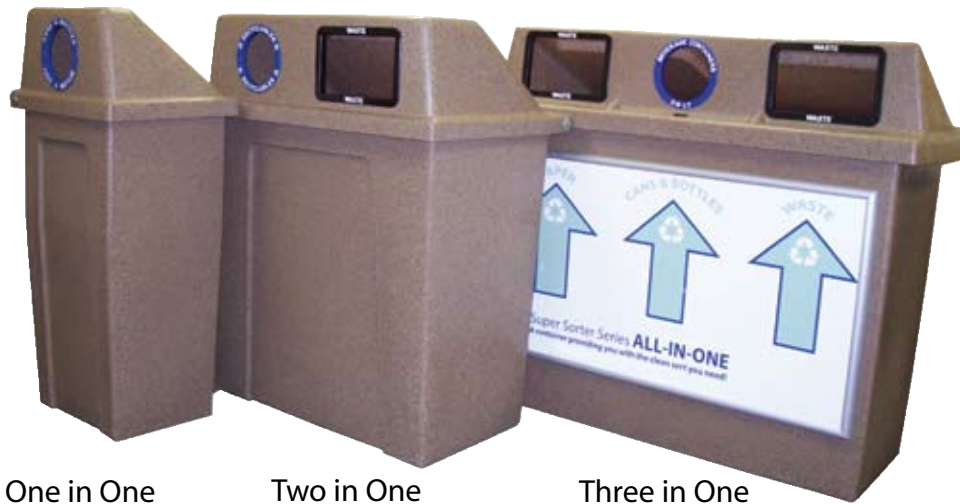

One in One

Two in One

Three in One

Why recycle if you're not getting a clean sort of recyclables?

- Excellent for high traffic areas.
- Indoor/outdoor use.
- Signage available.
- Multiple opening variations.
- Will not rust or dent.
- Various color options.
- Soft and hard ground mounting.
- Durable plastic liner included.
- Optional plastic bag hooks available.
- Optional wheels available.

Hot Stamped Openings Will Not Fade or Peel

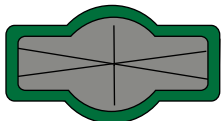

Mixed Recyclables
10 1/2" x 5"

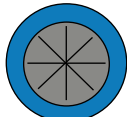

Cans / Bottles
3 1/4" or 5 3/4"



Paper / Newspaper
3" x 13"



Paper / Newspaper
2" x 10.5"

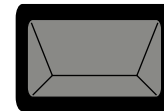

Plastic / Waste
6" x 10"



Self Closing Flap
6" x 10"

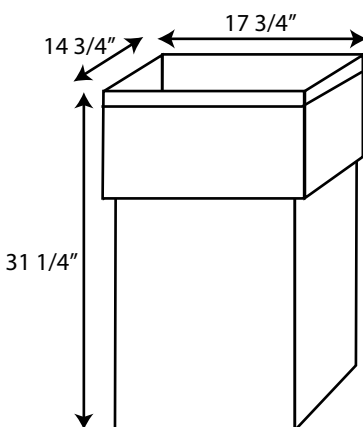

Super Sorter Liner

- Easy to remove.
- Durable.
- Made of post consumer recycled content.
- Bottom grip for dumping.
- 30 US Gallon capacity.

Dimensions: 17.75" L x 14.75" W x 31.25" H

 **Minimum 25 - 55 % Post Consumer Content**

Attractive and Durable Containers ... Built to Last.

Product Color Chart



Premium Sand Stone (33)



Premium Granite Grey (32)



Granite Blue (07)



Granite Red (34)



Granite Grey (21)



Granite Green (10)



Basic Blue (05)



Beige (22)



Light Grey (20)



Black (23)

One in One

Dimensions:
20.5" L x 15.75" W x 45" H
Capacity: 30 US Gallon



Two in One

Dimensions:
37.25" L x 23.25" W x 45" H
Capacity: 60 US Gallons



Three in One

Dimensions:
49" L x 23" W x 45" H
Capacity: 90 US Gallons



 Minimum 25 - 55 % Post Consumer Content

RECYCLING IS ONLY EFFECTIVE WITH A QUALITY SORT

Better Than Stone



- Great for recycling or waste.
- Vertical opening keeps water out.
- Easy to open, lid hinges to the side. Container can be tucked up against a wall.
- Lighter than stone or concrete bins, so it can be easily transferred.
- Heavy rugged design is bottom heavy for stability.
- Optional self closing waste flap.
- Optional wheels available.
- Optional soft and hard ground anchor kits.
- Up to 4 openings.
- Comes with bag hooks.
- Optional rigid plastic liner.



Shown with plastic bag clip.



Optional rigid plastic liner



Lid hinges to the side!

Dimensions: 24" L x 24" W x 41.5" H.

Hot Stamped Openings Will Not Fade or Peel

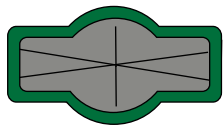

Mixed Recyclables
10 1/2" x 5"

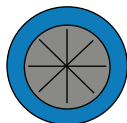

Cans / Bottles
3 1/4" or 5 3/4"



Paper / Newspaper
3" x 13"



Paper / Newspaper
2" x 10.5"

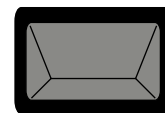

Plastic / Waste
6" x 10"



Self Closing Flap
6" x 10"

Product Color Chart

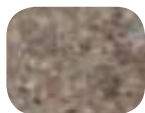

Premium Sand Stone (33)



Granite Blue (07)



Granite Red (34)



Basic Blue (05)



Beige (22)



Premium Granite Grey (32)



Granite Grey (21)



Granite Green (10)



Light Grey (20)



Black (23)



Minimum 25 - 55 % Post Consumer Content



PROUDLY MADE IN NORTH AMERICA !



True14

- Cross stacks.
- Easy grip handles.
- Lightweight and a durable container.
- Bottom impact feet.

Dimensions: 19.75" L x 15.75" W x 13.5" H.

True18

- Cross stacks with any 18 gallon container.
- Bottom impact feet.
- Optional lid available.

Dimensions: 23" L x 16" W x 14.25" H.

SIR21

- Cross stacks.
- Extra handle ribbing.
- Four handles.
- Optional lid available.

Dimensions: 22.25" L x 17.25" W x 15.5" H.

SIR24

- Cross stacks.
- Extra handle ribbing.
- Four handles.
- Optional lid available.

Dimensions: 22.25" L x 17.25" W x 17.25" H.



Custom colors
and stamping
available on all
curbside bins.



Optional Lid shown with True 18



Wall brackets & wheel packages are available for all of the above bins.



 **Minimum 25 - 55 % Post Consumer Content**

CUSTOM STAMPING  CUSTOM COLORS

Durable Industrial Carts

Heavy duty carts for your heavy duty workload.
You can't find these in your local hardware store.



Euro Style Carts



North American Carts

Multiple lid openings and locking mechanisms available.

Two Wheeled Carts available in a variety of

- Colors
- Shapes
- Sizes



Optional Openings

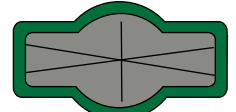

Mixed Recyclables
10 1/2" x 5"

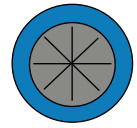

Cans / Bottles
3 1/4" or 5 3/4"

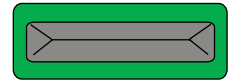

Paper / Newspaper
3" x 13"



Paper / Newspaper
2" x 10.5"

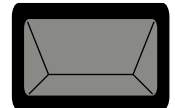

Plastic / Waste
6" x 10"



Self Closing Flap
6" x 10"

Document Destruction Containers

Euro Style Carts

North American Carts



PDC

Consoles

Shredinator

North America's largest and most comprehensive selection of document destruction containers for offices, deskside or centralized applications.

Minimum 25 - 55 % Post Consumer Content



PROUDLY MADE IN NORTH AMERICA !



Multi Purpose Cart

- 3" thread guard casters.
- Available in various colors.
- Easy to maneuver.
- 12, 15 and 16 cu. ft sizes available.
- Wheels available in corner pattern or diamond pattern (for easy dumping).

Dimensions:

Model 125A (12 cu.ft.): 35" L x 23" W x 25" H

Model 135A (15 cu.ft.): 37" L x 25" W x 26" H

Model 145A (16 cu.ft.): 38" L x 26" W x 28" H

Next Generation Carts

- The best cart ever ... anywhere ...
- Single wall body with double wall lip for affordable durability.
- Designed for maximum impact resistance.
- Polycore wheels with heavy duty casters for maximum rollability/maneuverability.

Dimensions:

Model 730B: 48" L x 31" W x 34.5" H - Capacity: 1000 lbs (454.5 kgs.)

Model 750B: 60" L x 31.5" W x 35.5" H - Capacity: 1000 lbs (454.5 kgs.)

Model 770B: 72" L x 35.5" W x 40" H - Capacity: 1500 lbs (681.8 kgs.)

Round Recycling & Waste Containers

Available in the following sizes:

10, 20, 25, 32, 44, 50, 55 Gallons



WE HAVE 100'S
OF DIFFERENT
CARTS

Several sizes of
Tilt Trucks



Minimum 25 - 55 % Post Consumer Content

RECYCLING PRODUCTS MADE FROM RECYCLED CONTENT

Specialty Products

Promotional Products

Promotional items are a proven, effective way to market your company, service or event.



NEW Mini 28 Quart



Mini Recycling Box



Recycling Bin Key Chain



Front End Bin Key Chain



Mini Cart



Little John



Mini Recycling Can



Mini Milk Crate Key Chain



Mini Cart Key Chain

Innovative companies rely on innovative products to get the word out.

Specialty Products



Food Waste Container



Heavy Duty Salt or Sand Utility Bins

(4 sizes available)

SOS 5.5 Cubic Feet

SOS 11 Cubic Feet

SOS 18 Cubic Feet

SOS 36 Cubic Feet



Wall Mounted Smoke Stand



Battery Bin



Smoke Stand



Minimum 25 - 55 % Post Consumer Content



PROUDLY MADE IN NORTH AMERICA !

